

CMG Compact Motor Gear

Model range CMG 05 - CMG 601
for torques from 500 Nm to 150,000 Nm

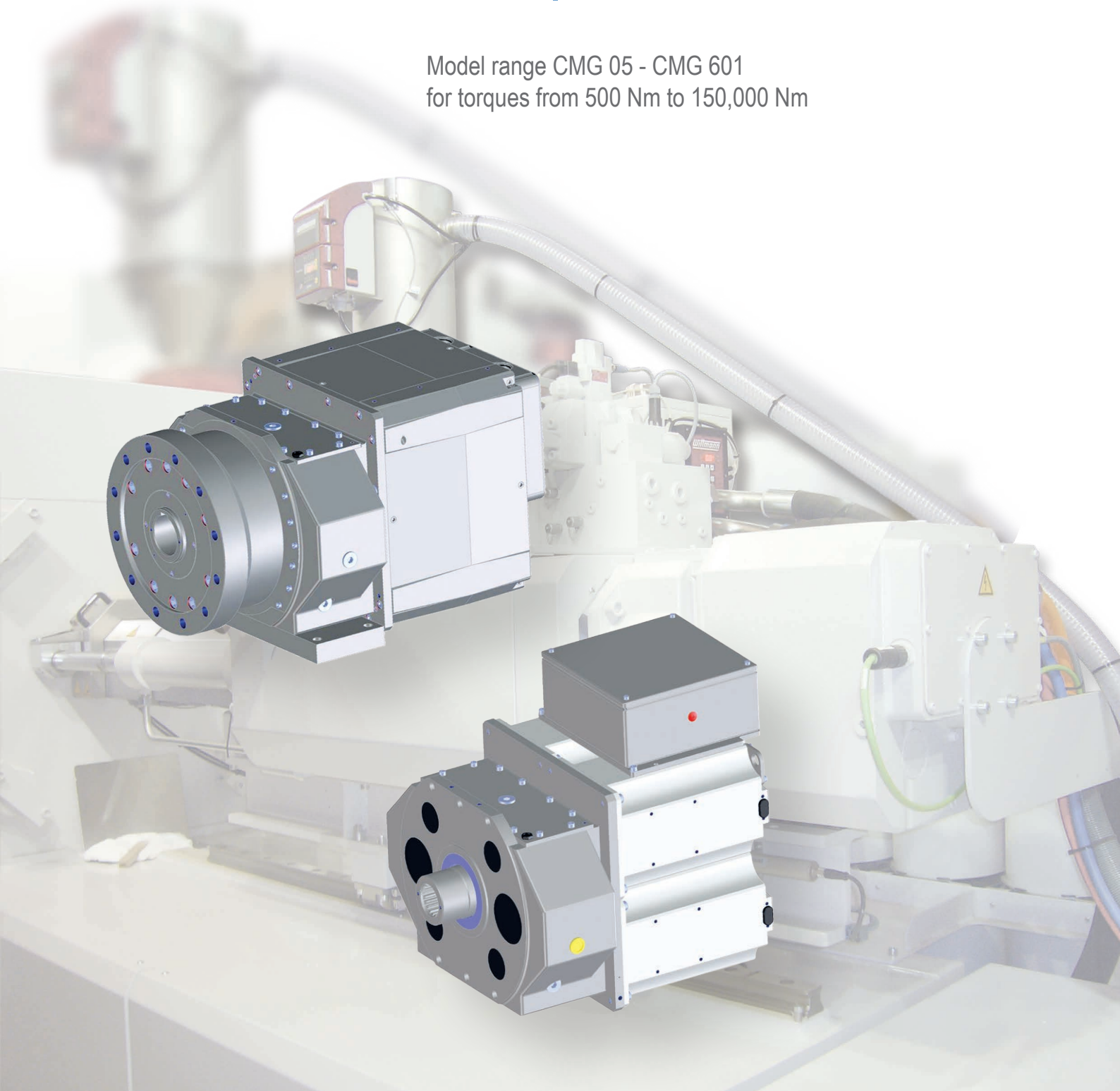

Model range CMG 05 - CMG 601

CMG Compact Motor Gear

The name of this series says it all. A CMG drive provides an enormous density of performance in the smallest of spaces.

The idea behind the development of this compact drive was to implement the performance density of a multi-piston hydro-motor in a new electric drive.

Originally designed for driving plastic machines, the CMG series now plays a major role in many fields. This drive is found in mixers, agitators, ball mills, shredders or extruders, wherever high performances and torques are required.

The main features of this series are four short three-phase current motors which are arranged in one housing around a central hollow bore. The four pinions of the motors engage a common drive gear wheel. This avoids transverse forces on the drive bearing and the low circumferential speeds ensure extremely quiet operation.

The four motors develop an electrical behaviour that is the same as a normal three-phase current asynchronous motor. The motor assemblies are especially designed for frequency inverter operation.

Protective devices such as cold conductor sensors are standard, encoders for speed control optional as required.

The CMG Compact Motor Gear has liquid cooling as standard to dissipate the heat losses of the motors. The CMG cooling circuit requires no pipework apart from the hoses for feeding and discharging the cooling fluid.

The cooling circuit can be controlled by PT1000 temperature sensors of the motor winding.

Use of a cooling water control reduces the coolant consumption, increases the performance of the drive and prevents condensation on a cold motor.

Applications with CMG drives

- Extruder
- Plasticizing drive on injection molding machines
- Agitators, Mixer
- Shredder
- Ball mills etc.

Model range CMG 05 - CMG 601 – Design and function

Structure and function

The CMG Compact Motor Gear consists of two sub-assemblies, the motor section and the gear section.

Motor section

The motor section is a multiple motor unit with four single motors. The motor assemblies are arranged symmetrically around a central hollow bore. The individual motor assemblies are internally connected respectively in start circuit and then connected in parallel to the terminal board.

This structure makes use of the asynchronous motor characteristic, adjustment of the motor torque to the load torque, to synchronise the individual motor assemblies. The four motors are mechanically coupled by the teeth of the drive pinion engaging in a common gear wheel. All motors then turn at the same speed under this forced condition. The total power taken off the drive shaft is distributed evenly between the motors.

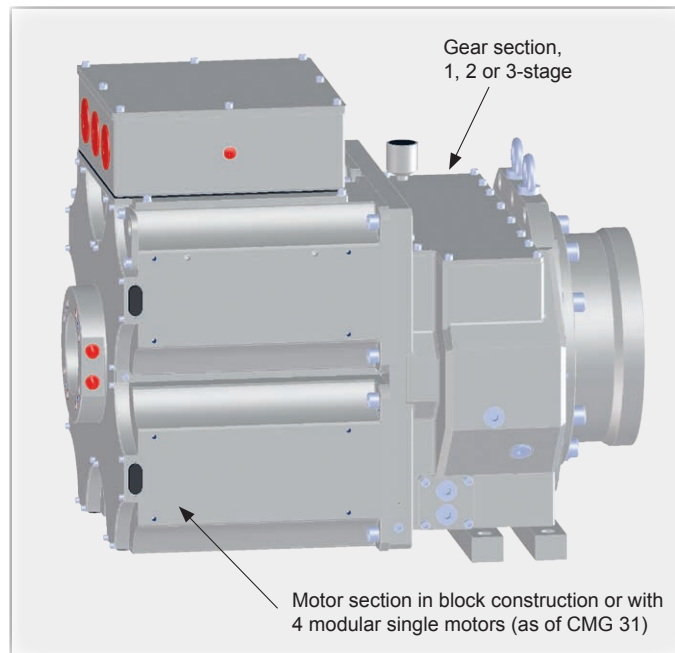

The compact dimensions and the small rotor diameters create the conditions for the high dynamic response of the motor unit.

The motor unit is connected to the mechanical part, the compact gear, respectively between the rotor and the input pinion shaft. This connection – the rotor shaft serves as a hub – is a friction-type tapered connection.

Gear section

The gear section is an oblique toothed spur gear with a symmetrical structure. The teeth of the pinion shafts and gear wheels are hardened and ground. The so-called compact gear is available as a single-stage, two-stage or three-stage version.

Both types have a central PTO, with a hollow output shaft as standard. In this design, the teeth engagement forces in the output stage balance each other out in radial and circumferential directions. This relieves the load on the output bearing and results in optimum efficiency.

The multiple tooth engagement ensures high specific performance. A CMG Compact Motor Gear achieves a considerable reduction in the installation space in comparison with a conventional drive (water-cooled three-phase current motor + spur gear).

The small dimensions of the drive pinion ensure a low moment of mass inertia and also produce lower circumferential speeds than with conventional spur gears. The CMG Compact Motor Gear therefore sets new standards with regard to operating noise.

The acoustic pressure level is much lower in comparison with standard gears.

The coaxial structure of the gear in combination with the hollow output shaft creates a compact drive which especially demonstrates its advantages in plug-on applications. In the field of drives for plastic machines, for example, these are the possibility of pulling out the screw backwards through the motor or heating/cooling supply of the screw or machine shaft through the hollow output shaft.

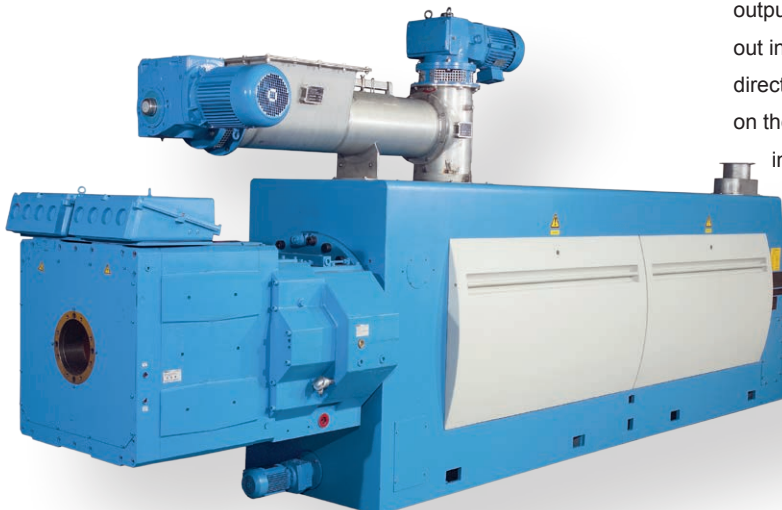

One CMG 400 as a drive for a screw press.

Model range CMG 05 - CMG 601 – Design and function

1-stage gear version

- 4-fold tooth engagement
- four oblique toothed pinions drive a common PTO gear wheel
- transmissions up to $i = 12$ are possible
- standard version with hollow output shaft

2-stage gear version

- 2 x 2 tooth engagements
- two oblique toothed pinion shafts each drive a common adapter gear wheel
- summing of the adapter gear wheels by a pinion shaft to a common PTO gear wheel
- transmissions up to $i = 47$ are possible
- standard version with hollow output shaft

Properties and advantages of the modular single motors

- individually removable motors allow greater servicing convenience
- greater operational reliability and longer service life
- shorter downtimes
- The system allows emergency operation in the event of problems with a single motor
- Operation with reduced performance is possible while a motor is being repaired
- The individual housings offer the possibility of winding optimisation.

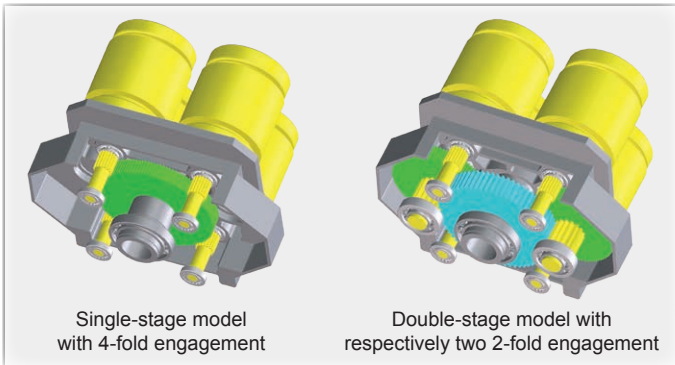
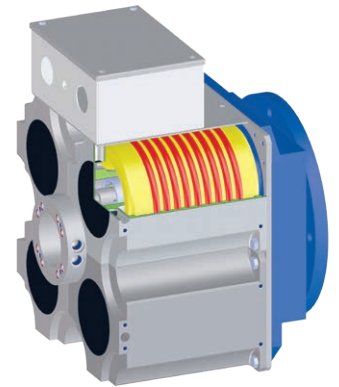
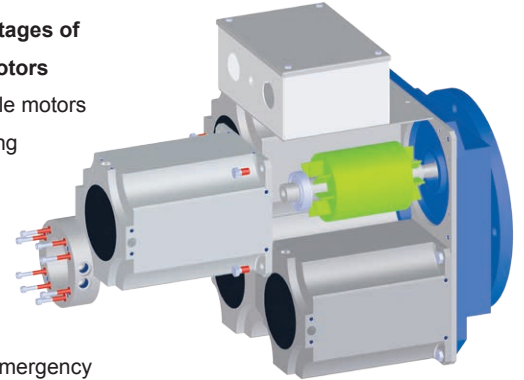

Single-stage model with 4-fold engagement

Double-stage model with respectively two 2-fold engagement



Modular CMG Compact Motor Gears in system operation

New cooling concept

- effective water cooling
- very good heat transition from the stator to the copper pipe and housing
- only one water connection for all four motors
- closed cooling circuit – separation of the cooling medium from the die-cast housing (no additional seals)
- cooling coil with constant cross section, optimised flow, therefore less sensitive to soiling
- parallel flow means constant temperature distribution.

The basic dimensions of the modular design are comparable with the block construction, retrofitting is possible without changing the machine connection.

Model range CMG 05 - CMG 601 – Technical data

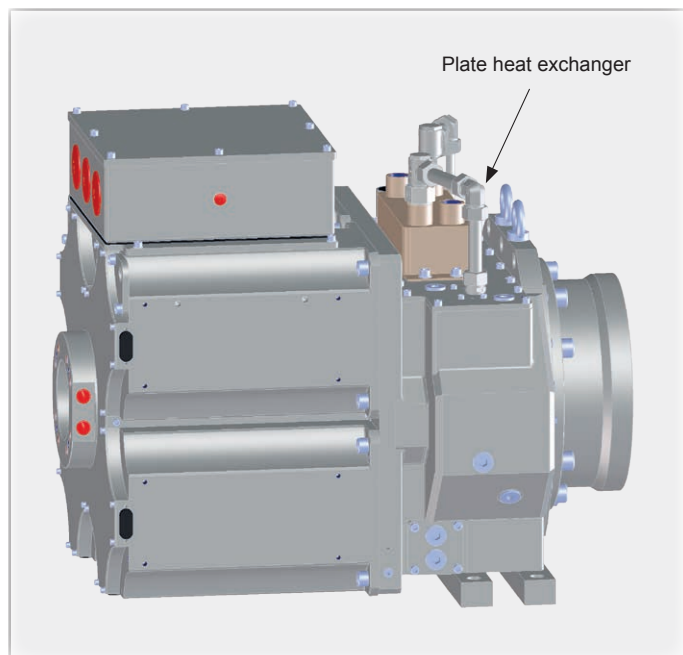

Gear cooling with plate heat exchanger

In the standard version, the gear is cooled by an integrated cooling coil. For greater powers, it is recommended to install a plate heat exchanger. This cooling principle represents a very effective, economical and proven solution.

Temperature sensor can be installed in the gear housing to monitor the oil temperature.

Incremental rotary encoder

An incremental rotary encoder is installed in the hollow shaft version for speed control. This is linked directly to the rotor shaft of one motor assembly. It is connected by a 12-pole flange socket with pin contacts.

Motor protection

All motor assemblies are equipped with PTC cold conductor full protection as standard. Two motor assemblies are fitted additionally with PT1000 temperature sensors. This allows cooling water control.

Performance data

Type CMG	05	10	20	30 / 31	60 / 61	120 / 121	240 / 241	400 / 401	601
Rated motor data	400 V / 50 Hz / 1,500 rpm								
Rated power P_N (kW)	6	18	22	60	88	147	256	440	1,000
Rated current I_N (A)	13.5	37	50	121	176	284	466	810	1,760
Rated torque M_N (Nm)	40	120	148	392	576	964	1,660	2,830	6,440
Operation on the frequency inverter	400 V / 87 Hz / 2,600 rpm								
max. power P_{max} (kW)	10.5	27	33	90	132	221	384	660	-
Rated current I_N (A)	23.5	63	87	210	305	492	810	1,660	-
Rated torque M_N (Nm)	35	105	127	338	496	830	1,430	2,440	-
Gear data	PTO torques depending on the gear reduction and drive power								
Torque 1-stage max. (Nm)	500	1,500	3,000	4,000	8,000	15,000	20,000	28,000	60,000
Torque 2-stage max. (Nm)	1,200	3,000	4,000	8,000	16,000	30,000	48,000	68,000	150,000
Torque 3-stage max. (Nm)	-	-	-	-	16,000	30,000	48,000	160,000	-
Rated reductions 1-stage	2.5 / 3.1 / 3.9 / 4.9 / 6.1 / 7.7 / 9.6 / 10.6 / 12								
Rated reductions 2-stage	11.9 / 13.8 / 15 / 18.8 / 20 / 21.5 / 23.5 / 27.5 / 29 / 33.2 / 37.2 / 47.5								
Rated reductions 3-stage (as of CMG 60 / 61)	23.5 / 43.3 / 45.8 / 54 / 66.4 / 74.4 / 81.9 / 84 / 100.8								

Model range CMG 05 - CMG 601 – Dimensions and weights

Main dimensions

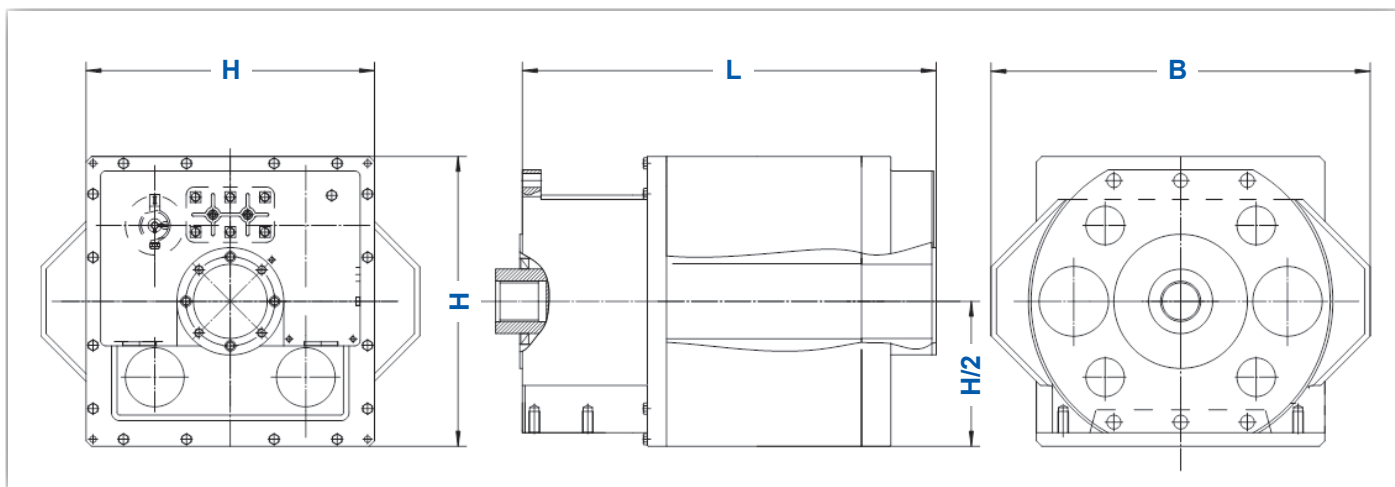

Type CMG	05	10	20	30 / 31	60 / 61	120 / 121	240 / 241	400 / 401	601
H (mm)	280	340	380	450	540	630	700	-	-
L (mm)	460	460	485	560	770	880	990	-	-
B (mm)	350	430	470	570	710	870	980	-	-

Weights*

Type CMG	05	10	20	30 / 31	60 / 61	120 / 121	240 / 241	400 / 401	601
Standard 1-stage (kg)	55-70	150-170	150-180	365-470	750-830	1,160-1,850	-	-	-
Standard 2-stage (kg)	85-100	170-190	170-200	415-520	850-930	1,290-1,980	2,000-2,340	3,200-3,500	-
Extruder 1-stage (kg)	65-80	175-195	210-240	465-570	870-950	1,410-2,000	-	-	-
Extruder 2-stage (kg)	95-110	195-215	240-270	515-620	970-1,050	1,540-2,130	2,400-2,740	4,000-4,200	-

* The specified weights are recommended values and may vary depending on the version.

Advantages in extruder drive:

Unlike a conventional sure gear with three-phase current motor is U or Z design, a CMG in extruder version has an absolutely short design at the same performance.

A great advantage here is the reduction in the space required by the gear section which results in a much lower gear oil requirement.



CMG 10 in extruder version

Model range CMG 05 - CMG 601 – Output versions

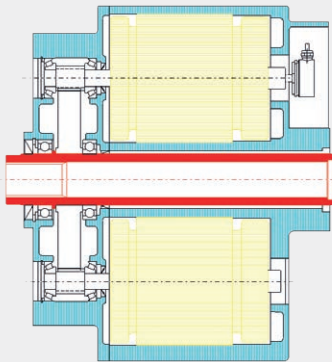

CMG drive with hollow shaft

The ideal design for all slip-on applications. The hollow shafts replace couplings and are available with a key slot or a spline; this permits free access to the drive shaft from the motor side. Requirements for high lateral forces, needed per example in agitators or mixers, are taken care for by locating the bearing support on the motor side, with this allowing for the best possible spacing between the bearings.

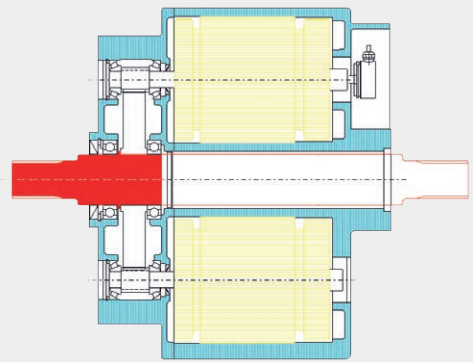

CMG solid shaft drive

The classic shaft form for the connection of drive to machine, available with either a drive shaft, or as a compact design form with drive shafts on both sides of the drive.

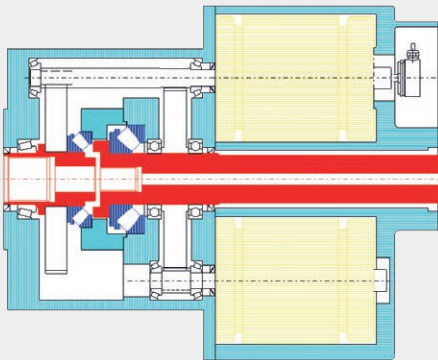

CMG power distribution system

A solution only possible due to the multiple motor drive. The distribution of the output torque into two independent output shafts, arranged in a co-axial design, opens absolutely new solutions in the area of power drive technology. With this compact drive, considerable performance increases are achievable in plastic and rubber extrusion processes.

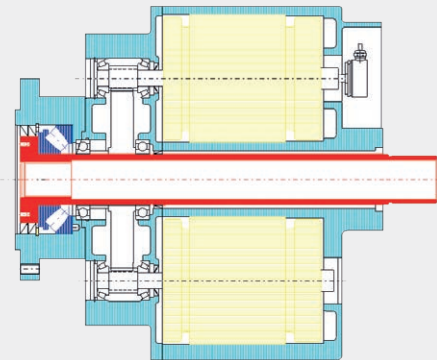

CMG extruder drive

Single screw extruder series. All of the advantages of the CMG system are combined for this application. Extremely short designed, no need for U or Z arrangement of the motor, free access to the screw for screw removal to the front or rear, drive for state of the art extruder design.

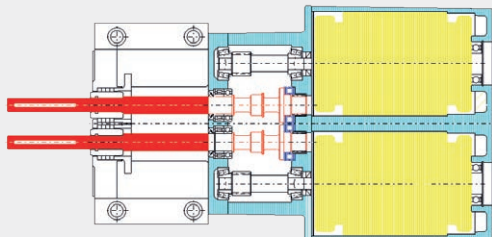

CMG double shaft drive

For this kind of gear drive all the advantages of the CMG drive show their potential, an ideal distribution of the output torque to the twin drive shafts, for co-rotating as well as for counter-rotating shafts.

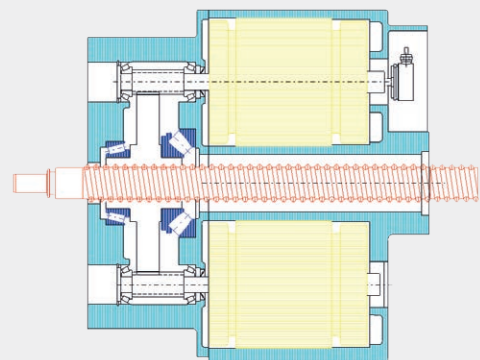

CMG linear drive

This application perfectly combines the advantages of the multiple motor drive and of the hollow shaft design of the drive unit. The drive spindle has free passage through both gear unit and motor, allowing a wide range of solutions in the field of linear drive technology.

More compact drive solutions for plastics technology

Extruder gear series FZ with directly mounted E-motor

Our water-cooled, modular three-phase current motors in which the rotor is connected directly to the gear drive shaft present a new version of compact extruder drives. The motors are our own development from the modular CMG concept and an extension to our product portfolio. The great advantage is that the motor and gear are optimally adapted to each other.



Injection and plasticizing gearbox series ZS-I/FZ

This series unites the linear movement for the injection and the rotary movement for feeding in a compact drive. Energy efficiency and low noise are the result of this drive with the additional advantages of short cycle times and high injection speeds and forces. An integrated force and distance measurement system ensures process reliability.



Consulting service

Call us if a standard gear is unsuitable for your area of application. Our experts will gladly advise you and help you to find the right solution for every technical challenge. We will also be happy to send you dimension sheets in PDF format in advance.



Further information

Knödler-Getriebe GmbH & Co. KG
Schönbuchstrasse 1
D-73760 Ostfildern

Phone 0049 - 711 - 448 140
info@knoedler-getriebe.de
www.knoedler-getriebe.de

Knödler
YOUR PARTNER FOR DRIVES